

KF CLAMP DIMENSION

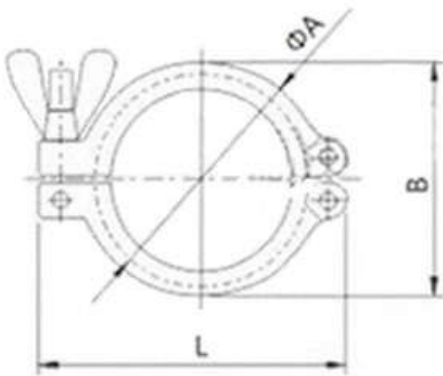

PUNARVI INDUSTRIES

Specification model: KF/NW10/16/25/40/50

Material : Aluminum

Type: Vacuum Accessories

Scope of application : Vacuum system

Specifications : 10/16/25/40/50

Product use: vacuum pipe connection

Size (mm)	A	B	L
KF16	35	45	62
KF25	45	55	73
KF40	60	70	90
KF50	80	96	123